

MANIGLIA A ROTAZIONE MOD. 6000

ROTATING FASTENER
MOD. 6000

Rev. 0 - 14. 05. 2023

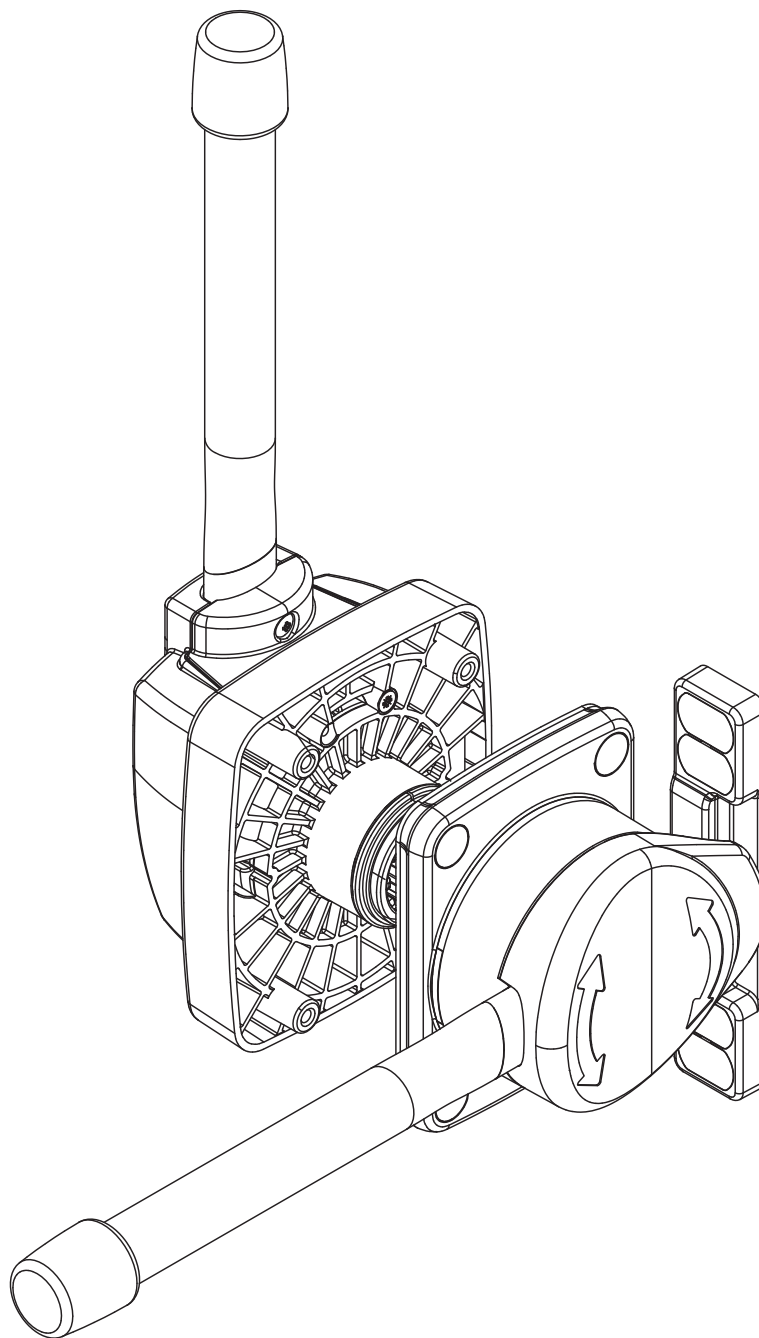

ISTRUZIONI DI MONTAGGIO / ASSEMBLING INSTRUCTIONS

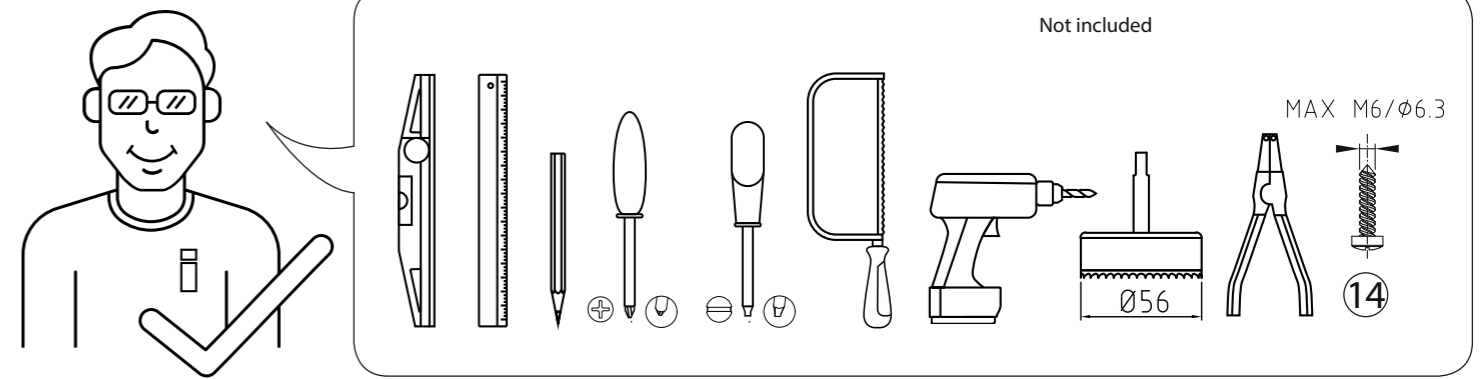

KIT PORTA PER 1 PUNTO
DOOR KIT FOR 1 POINT

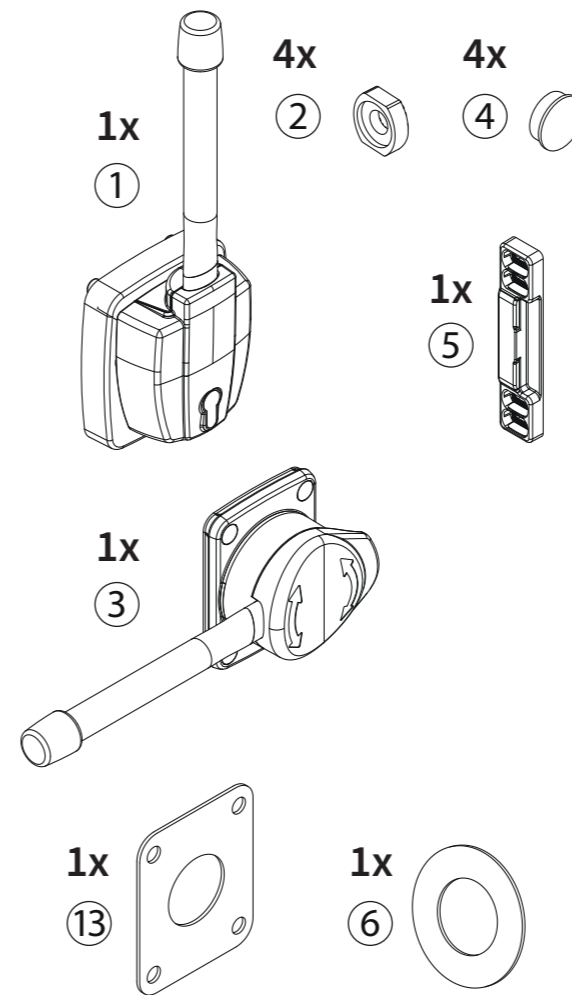

KIT PORTA PER 3 PUNTI
DOOR KIT FOR 3 POINTS

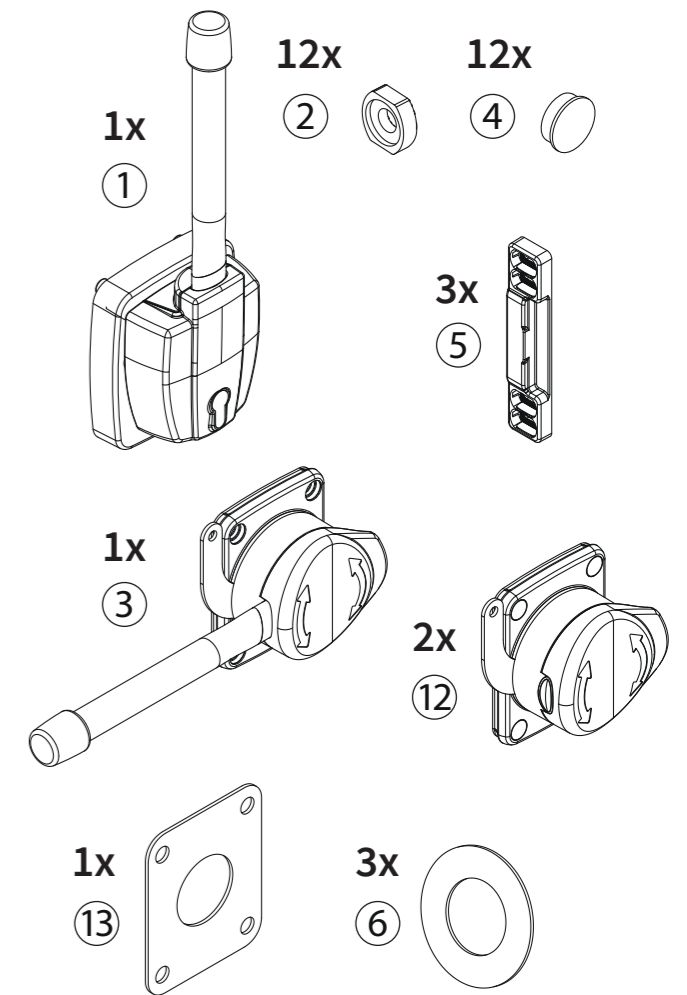

KIT SPESSORE PORTA
DOOR THICKNESS KIT

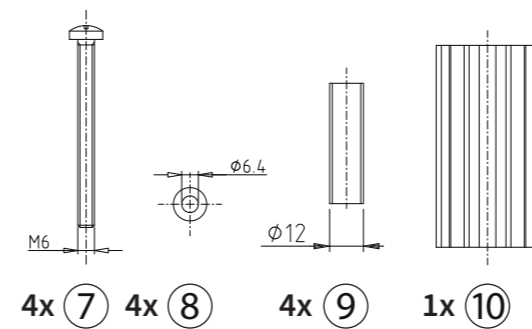

KIT SPESSORE PORTA 3 PUNTI + COPERTURA OPZIONALE
DOOR THICKNESS KIT FOR 3 POINTS + COVER (OPTIONAL)

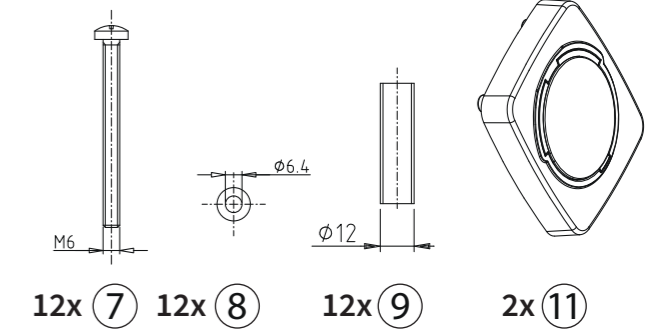

ILLUSTRAZIONI MONTAGGIO KIT PORTA 3 PUNTI - ILLUSTRATIONS MOUNTING KIT DOOR FOR 3 POINTS

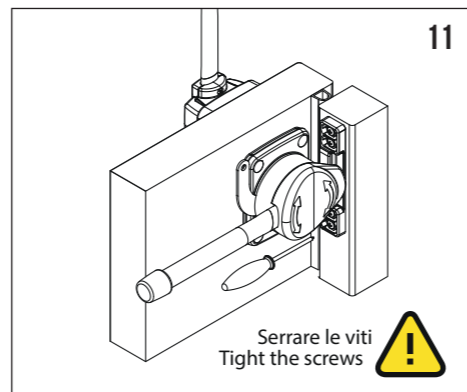
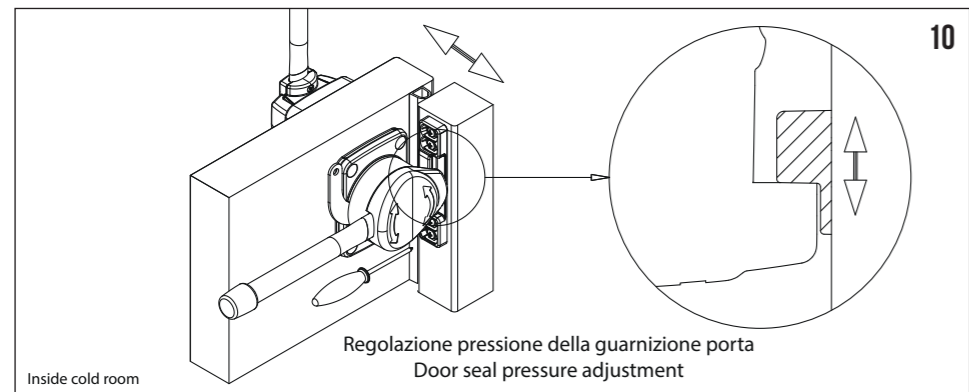
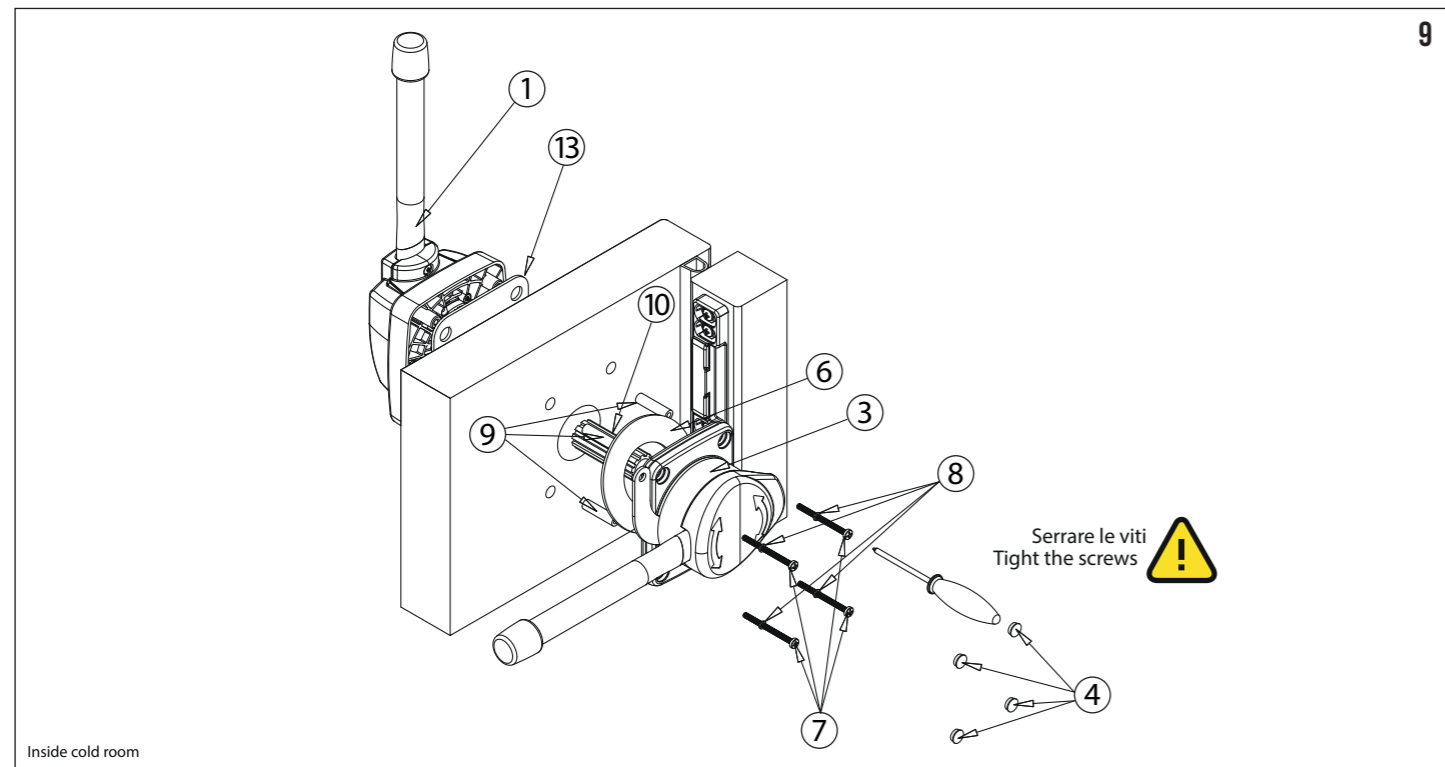
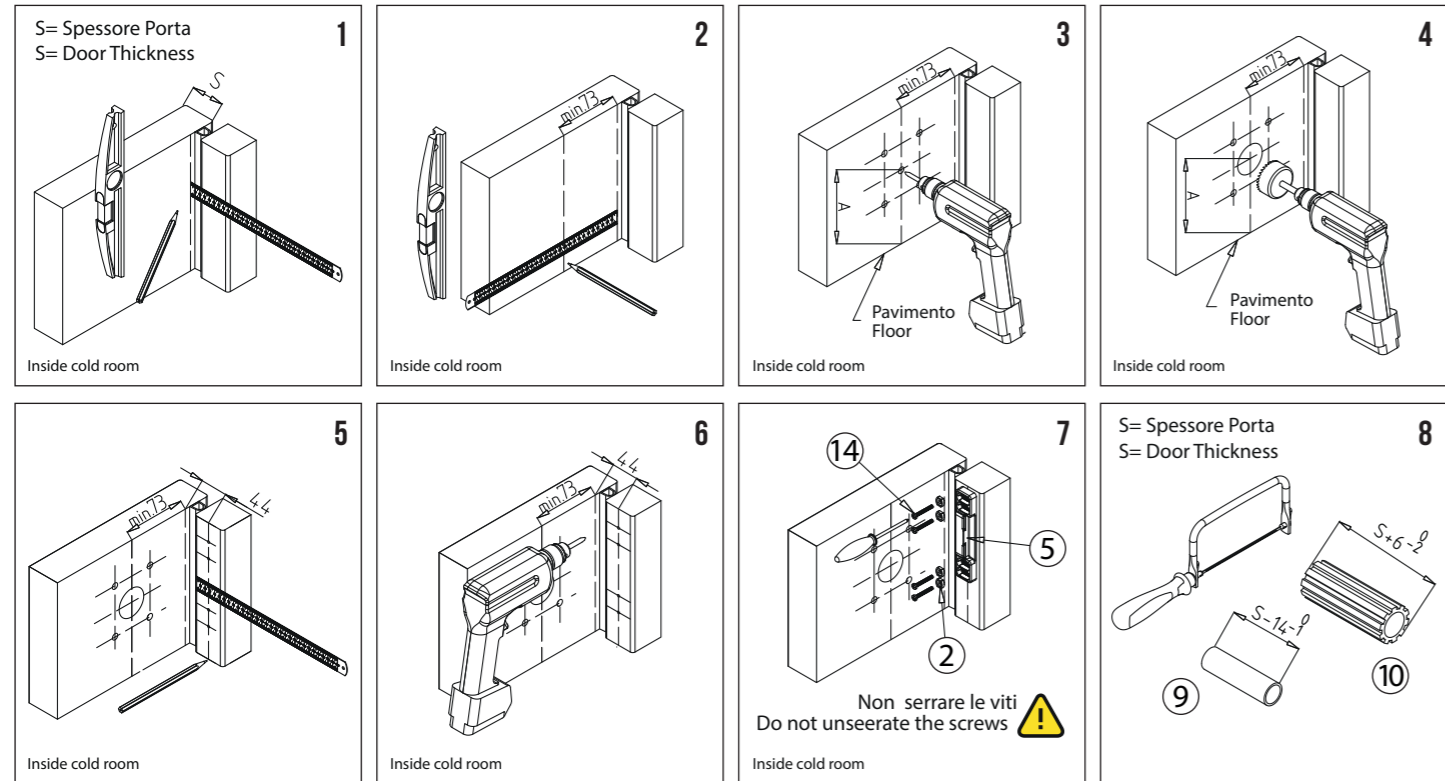

MONTAGGIO BLOCCHI - OPZIONE A - BLOCK ASSEMBLY - OPTION A

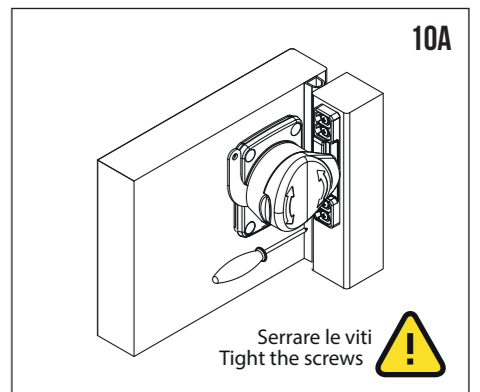
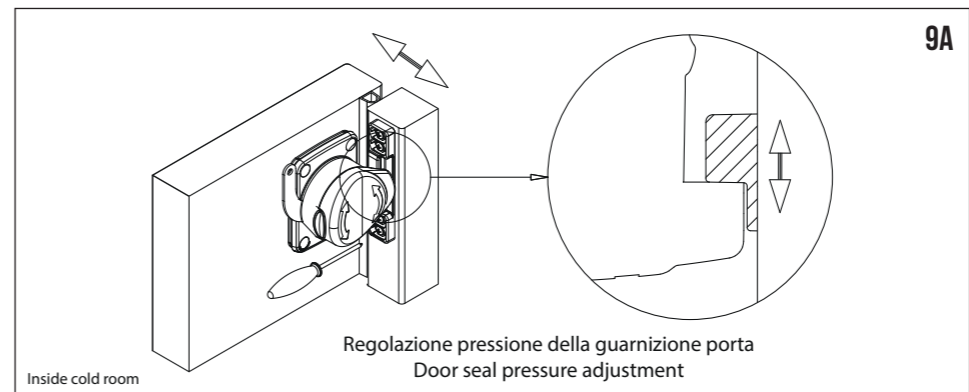
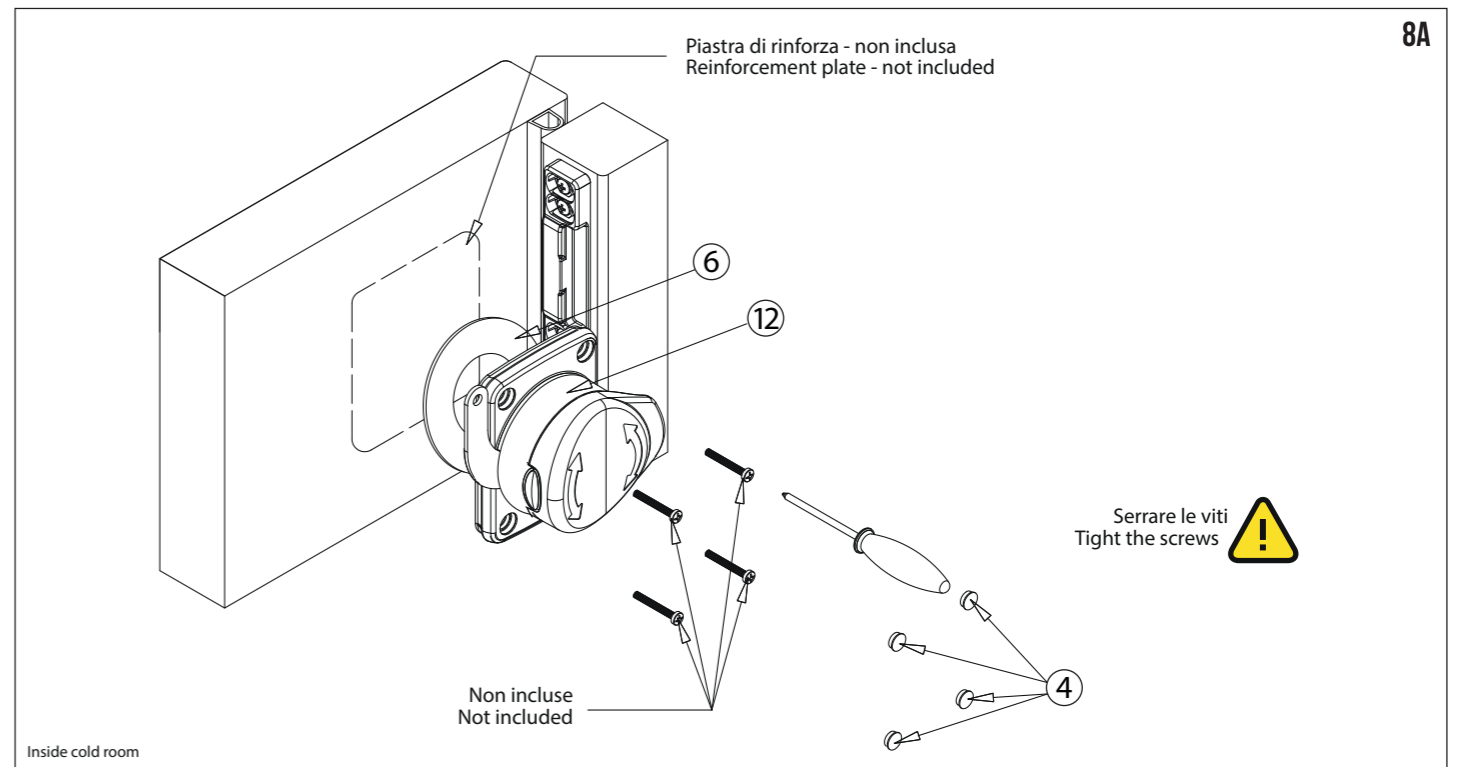
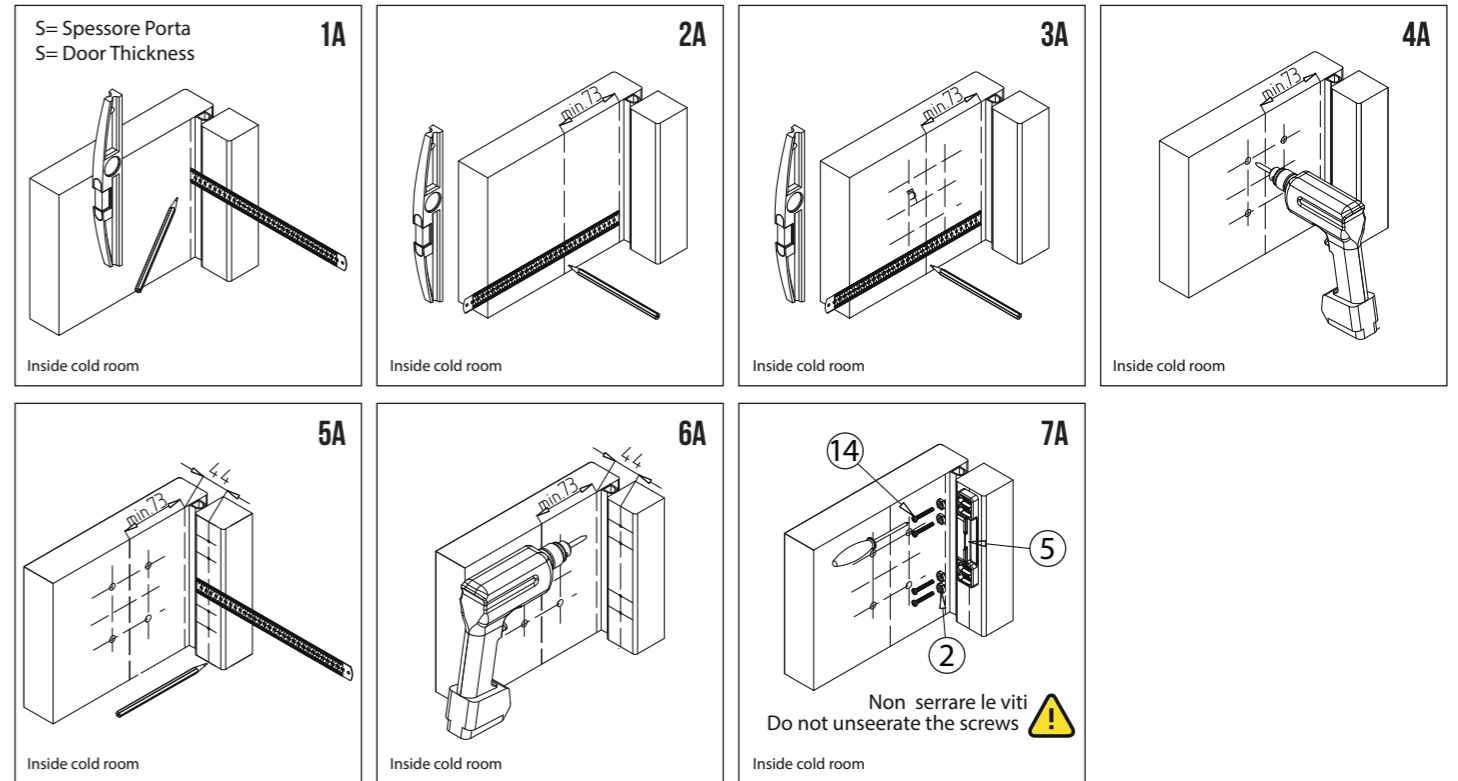

MONTAGGIO BLOCCHI - OPZIONE B - BLOCK ASSEMBLY - OPTION B

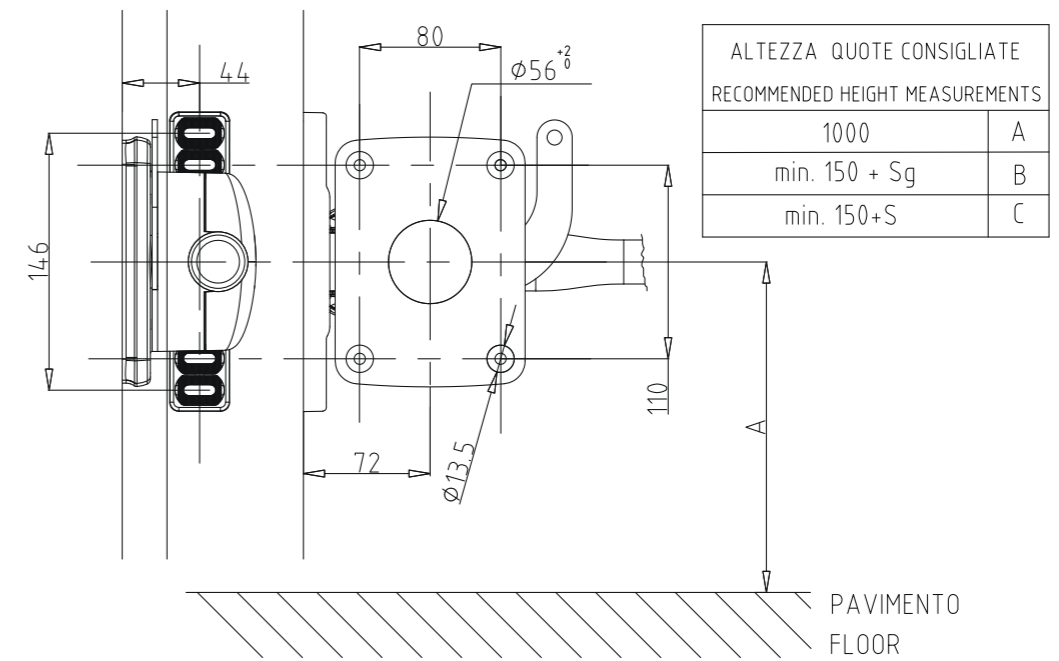
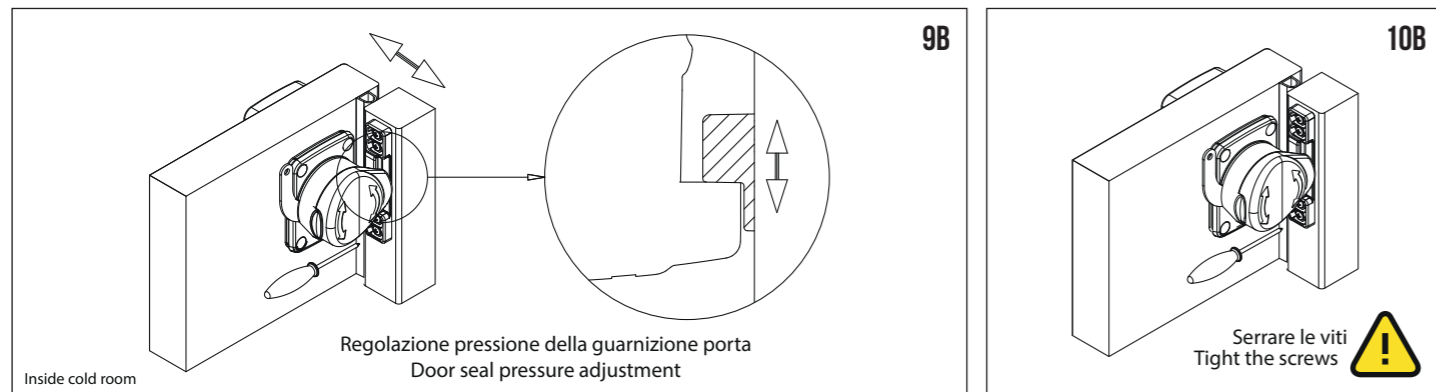
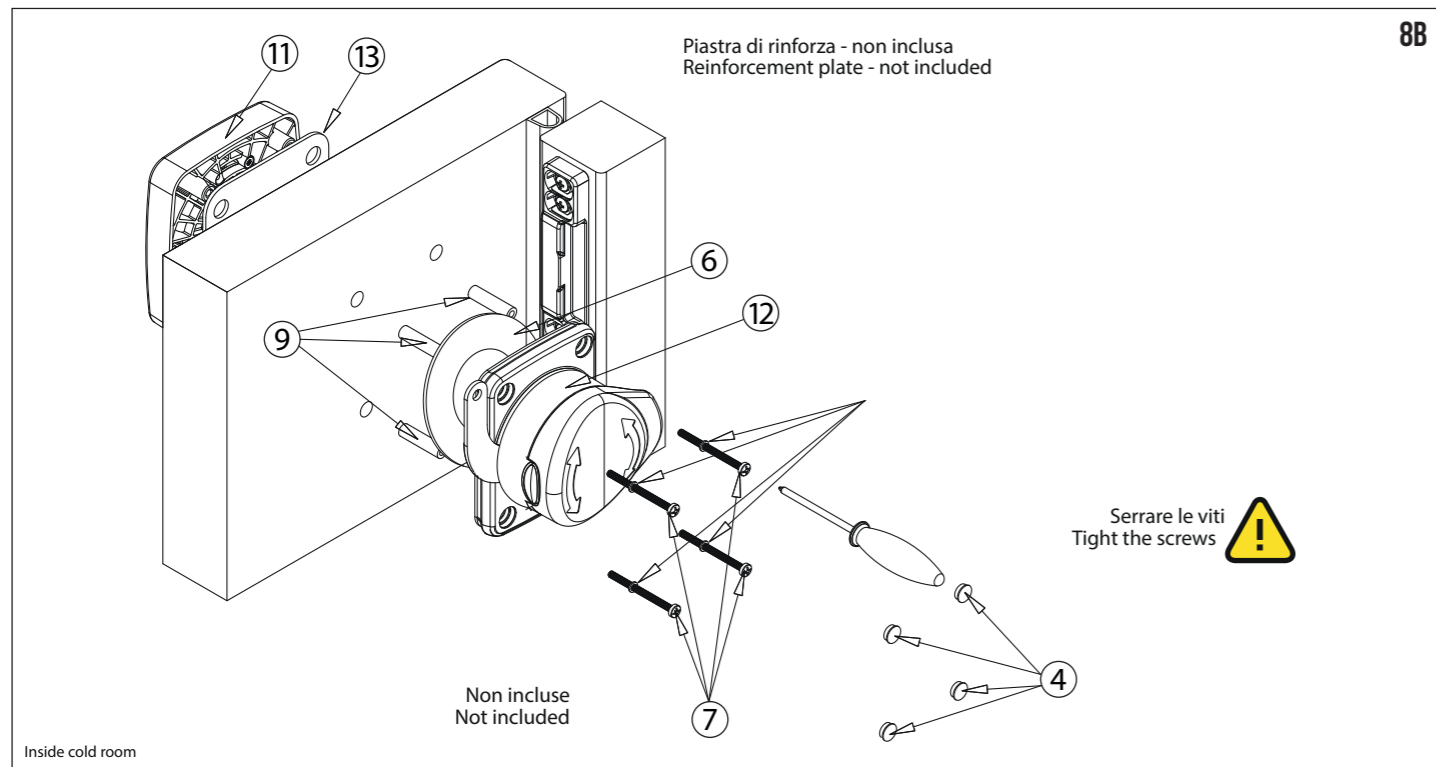
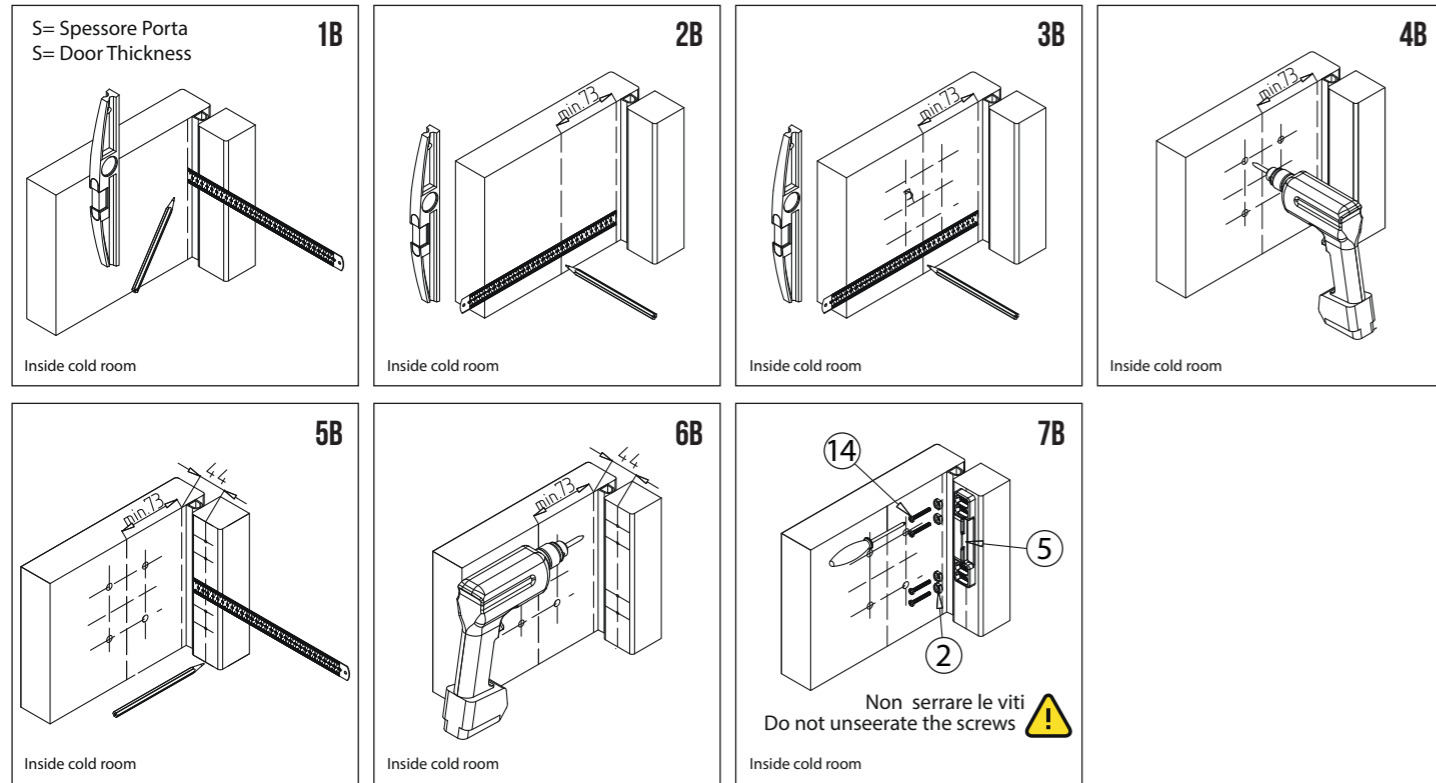

SCHEMA FORATURE PER KIT PORTA 3 PUNTI
DRILLING DIAGRAM FOR 3 POINT DOOR KIT

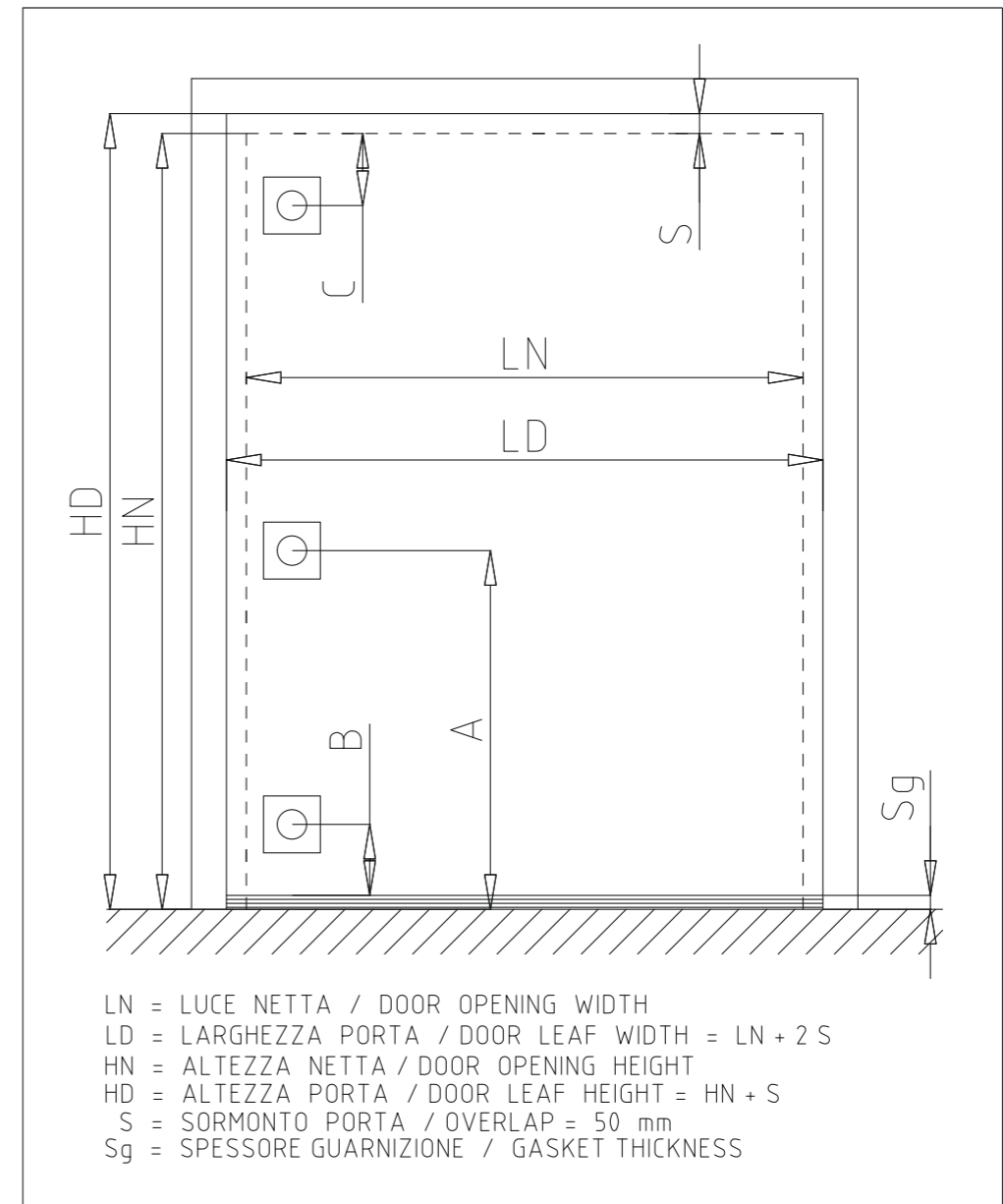



IK-INTERKLIMAT S.p.A.

HEADQUARTER

Via Remigio Paone, 2
20153 Milan (MI) Italy
Tel: +39 02 452817.1

**PRODUCTION
AND WAREHOUSE**

Via dell'Artigianato, 18
36022 Cassola (VI) Italy
Tel: +39 0424 85020