



Compressor  
Voltage Code : XG

# FH4518Y-XG1A

High Temp. Commercial (HP)

380-420V 3~ 50Hz / 460V 3~ 60 Hz

R134a / R513A

FH4518YXG1A

Conditions	Frequency	Nominal Cooling Capacity		Sound Power ISO3745 / ISO 3743-1
		Watts	BTU/h	
EN12900 / R134a	50 Hz / 60 Hz	3851 / 4689	13131 / 15989	69 dBA
EN12900 / R513A	50 Hz / 60 Hz	3919 / 4771	13363 / 16269	69 dBA

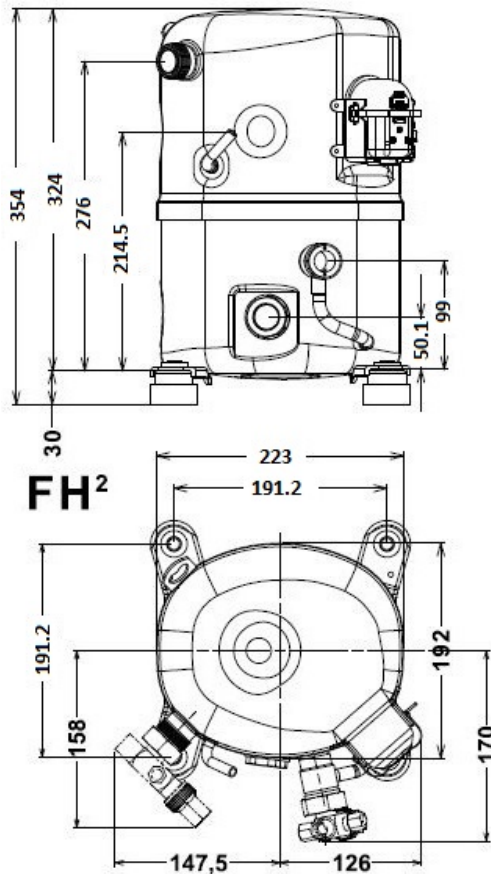

<b>Displacement (cc)</b>	48.5
<b>Net Weight (Kg)</b>	28.0
<b>Oil Quantity (cc)</b>	1140.0
<b>Oil Type</b>	Polyolester
<b>Expansion Device</b>	Capillary_Tube/Expansion_Valve
<b>Cooling</b>	Fan
<b>Main Winding (Ohm)</b>	19.6
<b>Current</b>	
RLA (A)	2.5   2.5
MCC (A)	4.9
LRA (A)	18
<b>Electrical Equipment</b>	TRI
<b>Overload</b>	Interne
<b>Refrigerating connection for OD</b>	
Suction Tube	15.9 (5/8")
Discharge Tube	12.7 (1/2")
Process Tube	6.35 (1/4")

\* EN12900 : T°Cond. 50.0°C / T°Evap. 5.0°C / T°Return gas temp.. 20.0°C  
T°Subcooling. 0.0K

Certificates :



Note : Tecumseh reserves the right to change information contained in this document without notification.



**Tecumseh**

<b>FH4518Y-XG1A</b>	<b>Tension XG : 380-420V 3~ 50Hz / 460V 3~ 60 Hz</b>
---------------------	--

Les performances sont données dans les **conditions EN12900** :  
 Condition Dew  
 The performance data are in **EN12900 conditions** :  
 Dew Condition

Gaz aspirés : 20.0 °C  
 Sous refroidissement : 0.0 K  
 Return gas : 20.0 °C  
 Subcooling : 0.0 K

© 2020 Tecumseh Products Company  
All rights reserved

**50 Hz R134a**

**N°User-357**

4   T condensation	5   T évaporation	(°C)	-25	-20	-15	-10	-5	0	5	10	15
<b>30</b>	1   P frigorifique	(Watt)	1041	1498	2054	2725	3526	4475	5586	6876	8360
	2   P absorbée	(W)	582	683	773	853	925	990	1049	1102	1153
	3   I absorbée	(A)	1.13	1.27	1.37	1.46	1.53	1.57	1.59	1.59	1.56
<b>40</b>	1   P frigorifique	(Watt)	758	1165	1648	2222	2904	3709	4654	5754	7024
	2   P absorbée	(W)	551	681	801	912	1016	1115	1208	1298	1385
	3   I absorbée	(A)	1.06	1.28	1.47	1.65	1.80	1.93	2.03	2.12	2.18
<b>50</b>	1   P frigorifique	(Watt)		870	1297	1793	2374	3054	3851	4779	5855
	2   P absorbée	(W)		665	814	955	1090	1220	1347	1471	1594
	3   I absorbée	(A)		1.19	1.47	1.73	1.97	2.18	2.37	2.54	2.69
<b>60</b>	1   P frigorifique	(Watt)			987	1423	1920	2494	3161	3935	4835
	2   P absorbée	(W)			833	1002	1166	1327	1485	1643	1800
	3   I absorbée	(A)			1.36	1.71	2.03	2.33	2.61	2.87	3.10

**60 Hz R134a**

**N°User-357**

4   T condensation	5   T évaporation	(°C)	-25	-20	-15	-10	-5	0	5	10	15
<b>30</b>	1   P frigorifique	(Watt)	1234	1815	2494	3288	4215	5293	6538	7968	9601
	2   P absorbée	(W)	715	825	925	1016	1101	1181	1259	1336	1414
	3   I absorbée	(A)	1.08	1.25	1.41	1.56	1.70	1.83	1.95	2.05	2.15
<b>40</b>	1   P frigorifique	(Watt)	836	1377	1997	2711	3539	4497	5603	6875	8329
	2   P absorbée	(W)	691	839	975	1101	1220	1333	1443	1550	1658
	3   I absorbée	(A)	1.01	1.23	1.43	1.63	1.82	2.00	2.16	2.32	2.47
<b>50</b>	1   P frigorifique	(Watt)		962	1521	2156	2884	3722	4689	5800	7075
	2   P absorbée	(W)		805	985	1155	1315	1469	1618	1763	1908
	3   I absorbée	(A)		1.19	1.45	1.70	1.93	2.16	2.37	2.58	2.77
<b>60</b>	1   P frigorifique	(Watt)			1091	1646	2273	2991	3817	4768	5862
	2   P absorbée	(W)			949	1169	1379	1581	1777	1968	2158
	3   I absorbée	(A)			1.45	1.75	2.03	2.31	2.57	2.83	3.07

1 = cooling capacity 2 = power input 3 = current 4 = condensing temperature 5 = evaporating temperature

**Nota : Tecumseh se réserve le droit de modifier les informations contenues dans ce document sans préavis.**

**Note : Tecumseh reserves the right to change information contained in this document without notification.**



**Tecumseh**

<b>FH4518Y-XG1A</b>	<b>Tension XG : 380-420V 3~ 50Hz / 460V 3~ 60 Hz</b>
---------------------	--

Les performances sont données dans les <b>conditions EN12900</b> :	Gaz aspirés :	20.0 °C
Condition Dew	Sous refroidissement :	0.0 K
The performance data are in <b>EN12900 conditions</b> :	Return gas :	20.0 °C
Dew Condition	Subcooling :	0.0 K

<b>50 Hz R513A</b>											
											<b>N°User-358</b>
4   T condensation	5   T évaporation	(°C)	<b>-25</b>	<b>-20</b>	<b>-15</b>	<b>-10</b>	<b>-5</b>	<b>0</b>	<b>5</b>	<b>10</b>	<b>15</b>
<b>30</b>	1   P frigorifique	(Watt)	1199	1694	2278	2962	3758	4678	5735	6940	8306
	2   P absorbée	(W)	647	749	836	914	985	1055	1128	1208	1299
	3   I absorbée	(A)	1.26	1.39	1.49	1.57	1.63	1.67	1.71	1.74	1.76
<b>40</b>	1   P frigorifique	(Watt)	853	1288	1796	2387	3075	3870	4785	5832	7023
	2   P absorbée	(W)	602	740	862	972	1075	1176	1277	1385	1502
	3   I absorbée	(A)	1.16	1.39	1.58	1.76	1.90	2.03	2.15	2.26	2.36
<b>50</b>	1   P frigorifique	(Watt)		948	1383	1886	2468	3142	3919	4812	5832
	2   P absorbée	(W)		708	866	1011	1148	1279	1411	1548	1693
	3   I absorbée	(A)		1.27	1.56	1.83	2.07	2.29	2.49	2.68	2.86
<b>60</b>	1   P frigorifique	(Watt)			1048	1466	1946	2502	3145	3887	4741
	2   P absorbée	(W)			871	1052	1222	1387	1551	1718	1891
	3   I absorbée	(A)			1.43	1.79	2.13	2.44	2.72	3.00	3.26

<b>60 Hz R513A</b>											
											<b>N°User-358</b>
4   T condensation	5   T évaporation	(°C)	<b>-25</b>	<b>-20</b>	<b>-15</b>	<b>-10</b>	<b>-5</b>	<b>0</b>	<b>5</b>	<b>10</b>	<b>15</b>
<b>30</b>	1   P frigorifique	(Watt)	1422	2053	2765	3574	4492	5534	6713	8044	9540
	2   P absorbée	(W)	794	905	1001	1088	1172	1259	1355	1465	1594
	3   I absorbée	(A)	1.20	1.37	1.53	1.67	1.81	1.95	2.10	2.25	2.42
<b>40</b>	1   P frigorifique	(Watt)	940	1524	2177	2913	3746	4691	5760	6968	8329
	2   P absorbée	(W)	755	911	1049	1174	1291	1406	1525	1654	1798
	3   I absorbée	(A)	1.10	1.33	1.54	1.74	1.93	2.11	2.29	2.48	2.67
<b>50</b>	1   P frigorifique	(Watt)		1046	1622	2268	2999	3829	4771	5839	7047
	2   P absorbée	(W)		858	1050	1224	1385	1541	1695	1855	2025
	3   I absorbée	(A)		1.27	1.54	1.80	2.04	2.26	2.49	2.71	2.94
<b>60</b>	1   P frigorifique	(Watt)			1153	1693	2305	3002	3799	4710	5747
	2   P absorbée	(W)			993	1228	1446	1653	1855	2058	2267
	3   I absorbée	(A)			1.52	1.84	2.13	2.42	2.69	2.95	3.22

1 = cooling capacity 2 = power input 3 = current 4 = condensing temperature 5 = evaporating temperature

**Nota : Tecumseh se réserve le droit de modifier les informations contenues dans ce document sans préavis.**

**Note : Tecumseh reserves the right to change information contained in this document without notification.**

© 2020 Tecumseh Products Company  
All rights reserved